

BRKIĆ IZUMI d.o.o. Zagreb Type: NCV 315L-2830 Working flow: 0.3-0.6 m ³ /s Static pressure: 1230-840 Pa Dynamic pressure: 517xVxV Pa Motor: KONČAR MES 5AZ 80B-2 Factory number: 30.. Production year: 20..	BRKIĆ IZUMI d.o.o. Zagreb Type: NCV 315L-1410/2830 Working flow: 0.16-0.3/0.3-0.6 m ³ /s Static pressure: 300-200/1230-840 Pa Dynamic pressure: 517xVxV Pa Motor: KONČAR MES 5AZPV 80B-4/2 Factory number: 30.. Production year: 20..
Type 7 Nameplate	Type 8 Nameplate

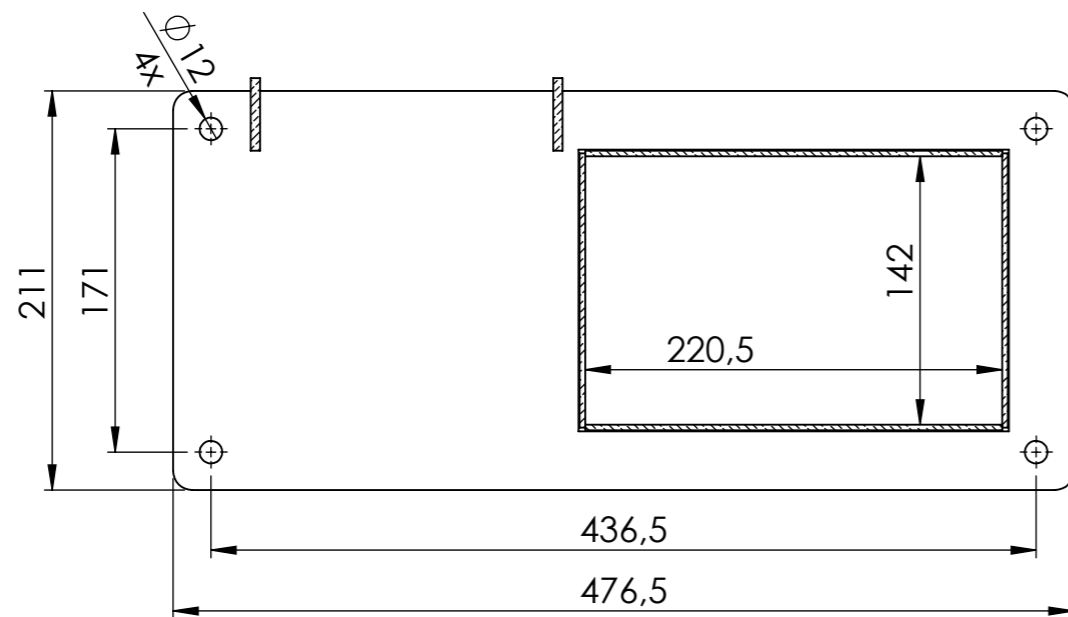
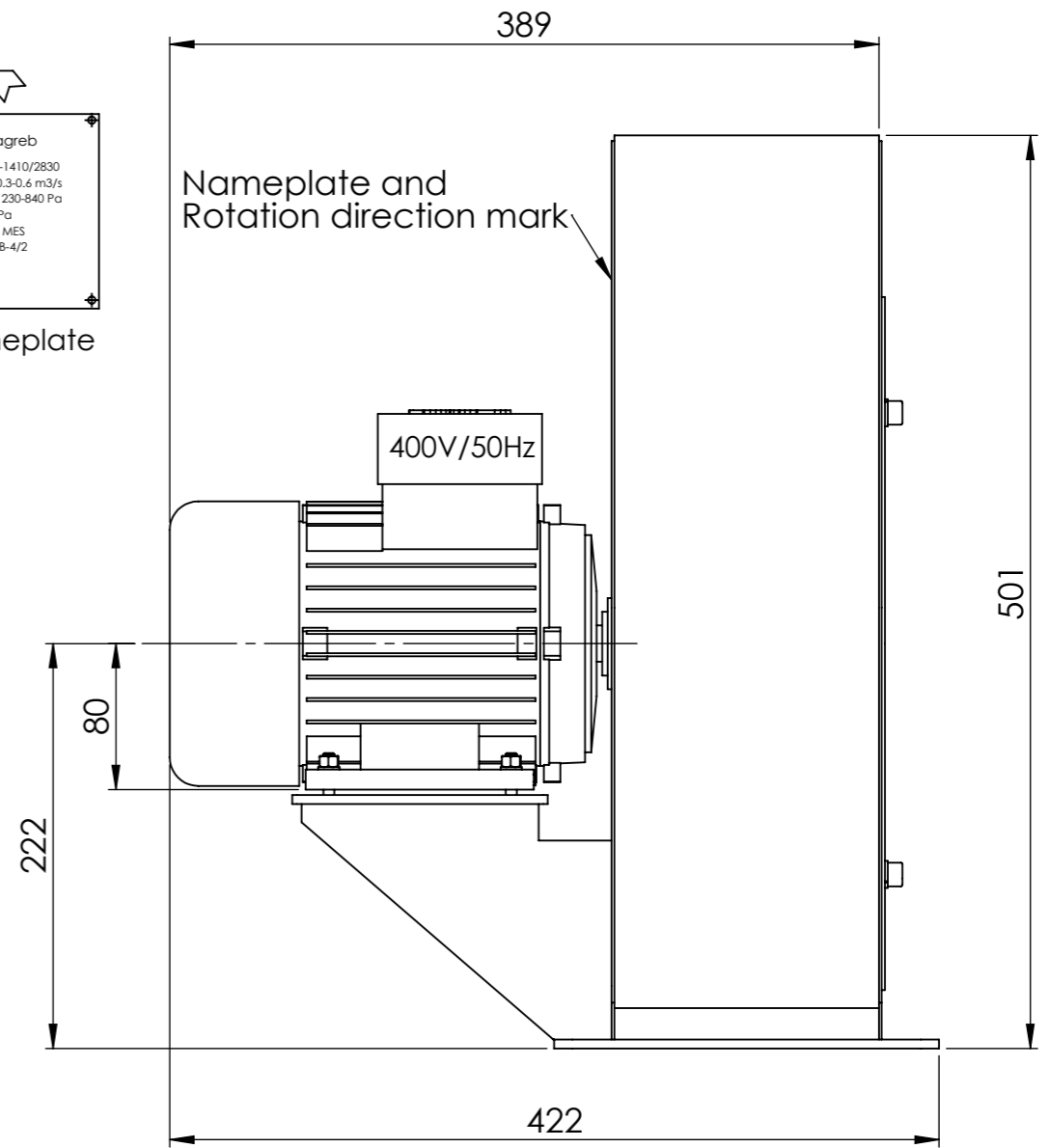

SECTION A-A

Fan wheel for all types is made from steel			
Designation	Spiral casing material	Part No.	Mass (kg)
Type 7 NCV 315S-2830	Steel	BI 34125	29
Type 7 NCV 315S-2820	AlMg3	BI 34129	22
Type 8 NCV 315S-1410/2830	Steel	BI 34133	29
Type 8 NCV 315S-1410/2830	AlMg3	BI 34137	22

Type of device:	Series:	Direction:
Centrifugal ventilator	NCV 315S	Exhaust Down
BRKIĆ IZUMI ZAGREB	Sheet size: A3	Dimensions in mm Tolerances ±1 unless shown
		First angle projection
		Drawing sheets: 1/1

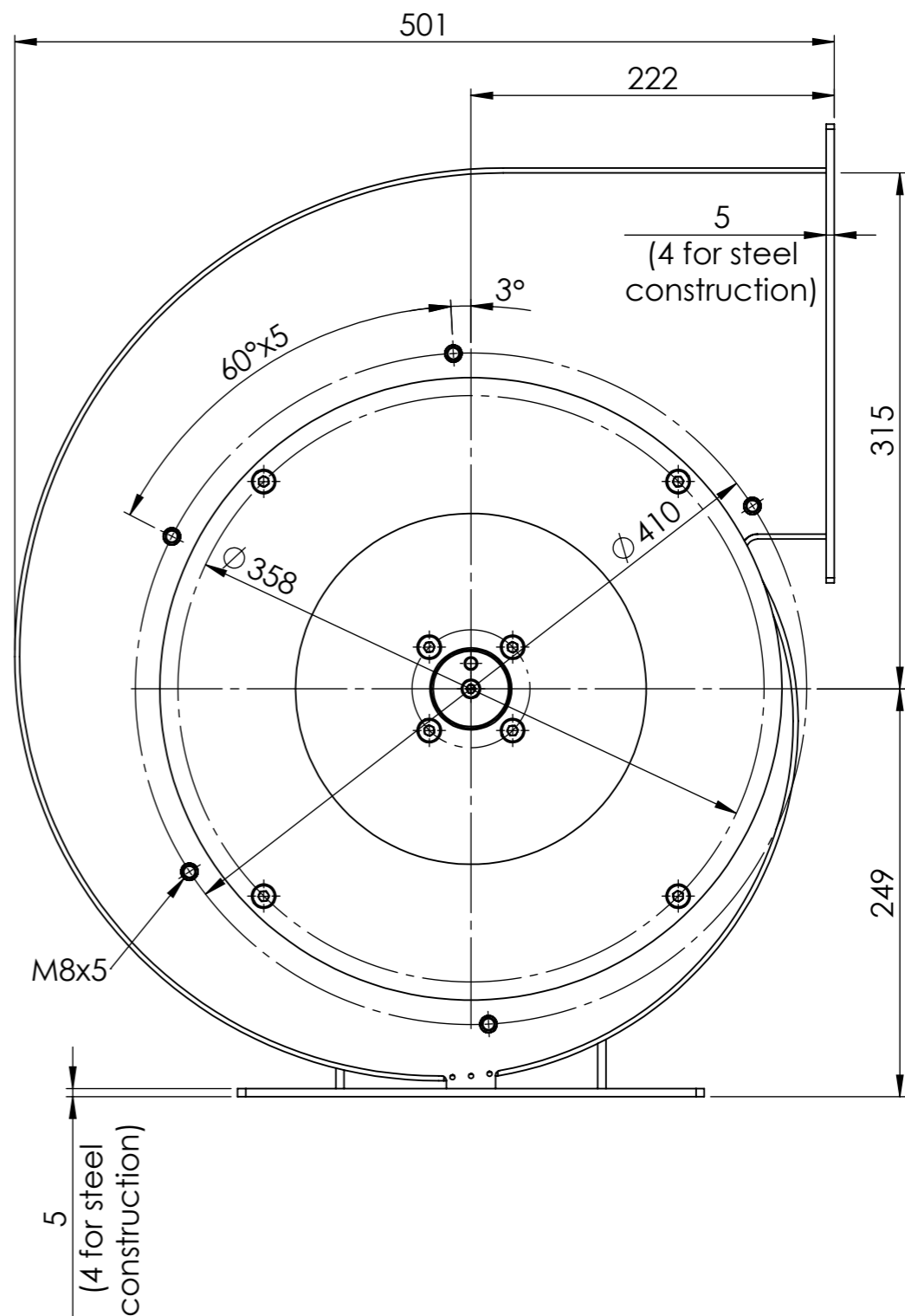
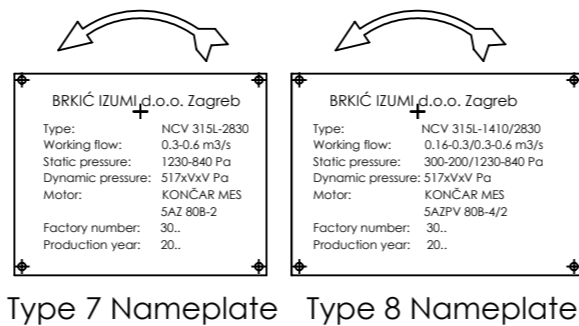
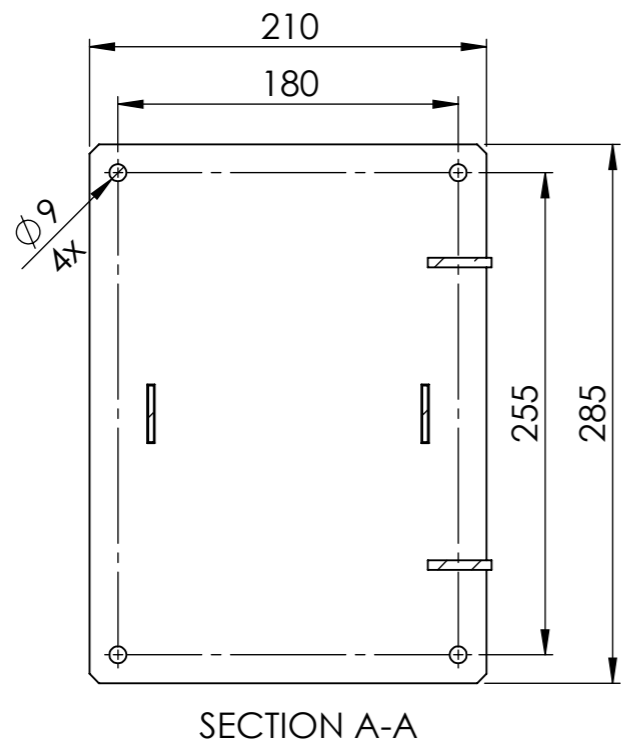
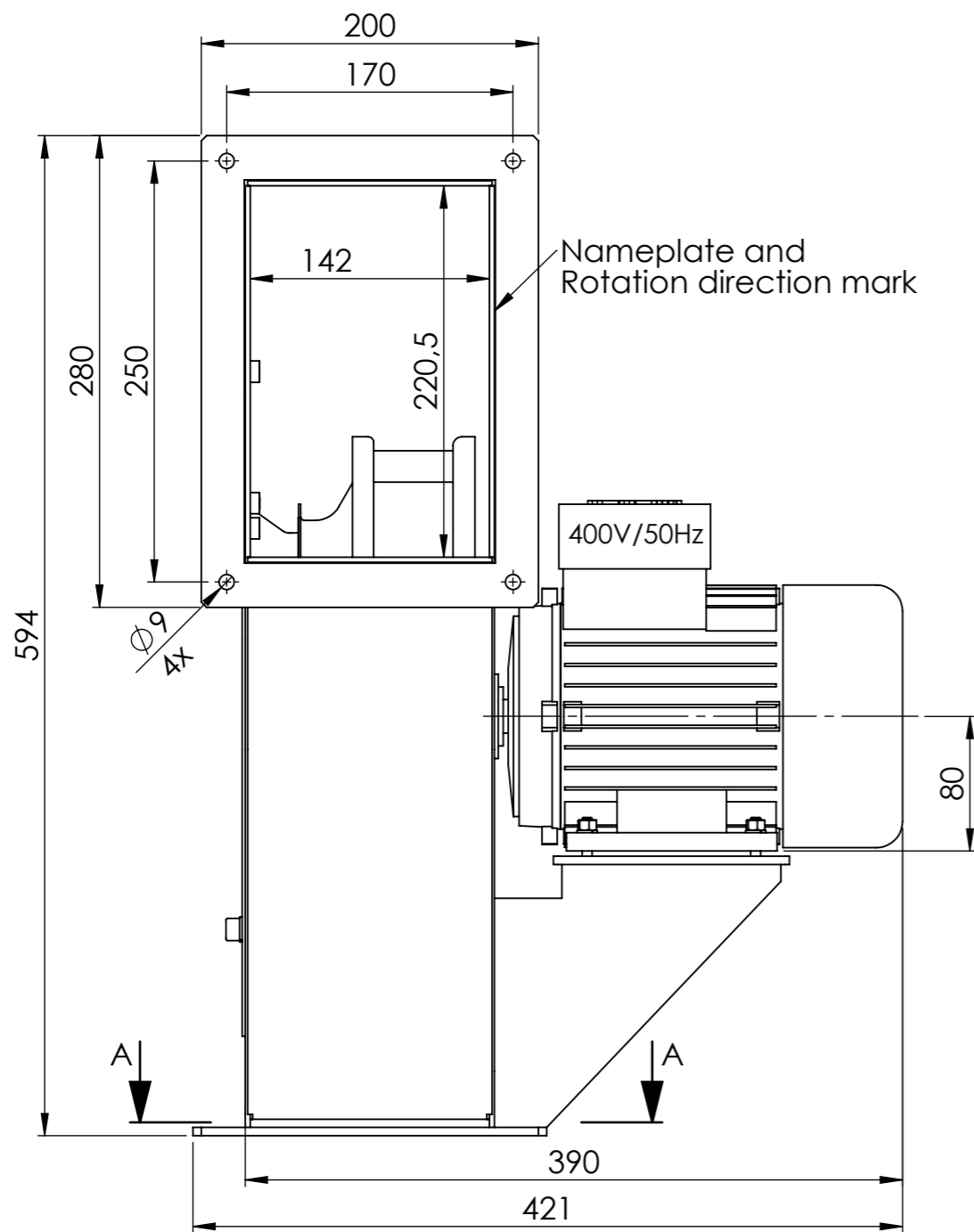

Fan wheel for all types is made from steel

Designation	Spiral casing material	Part No.	Mass (kg)
Type 7 NCV 315S-2830	Steel	BI 34126	30
Type 7 NCV 315S-2820	AlMg3	BI 34130	23
Type 8 NCV 315S-1410/2830	Steel	BI 34134	30
Type 8 NCV 315S-1410/2830	AlMg3	BI 34138	23

Type of device: Centrifugal ventilator	Series: NCV 315S	Direction: Exhaust Right
BRKIĆ IZUMI ZAGREB	Sheet size: A3	Dimensions in mm Tolerances ±1 unless shown
		First angle projection
		Drawing sheets: 1/1

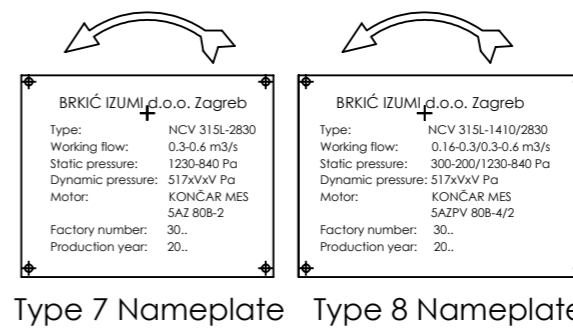
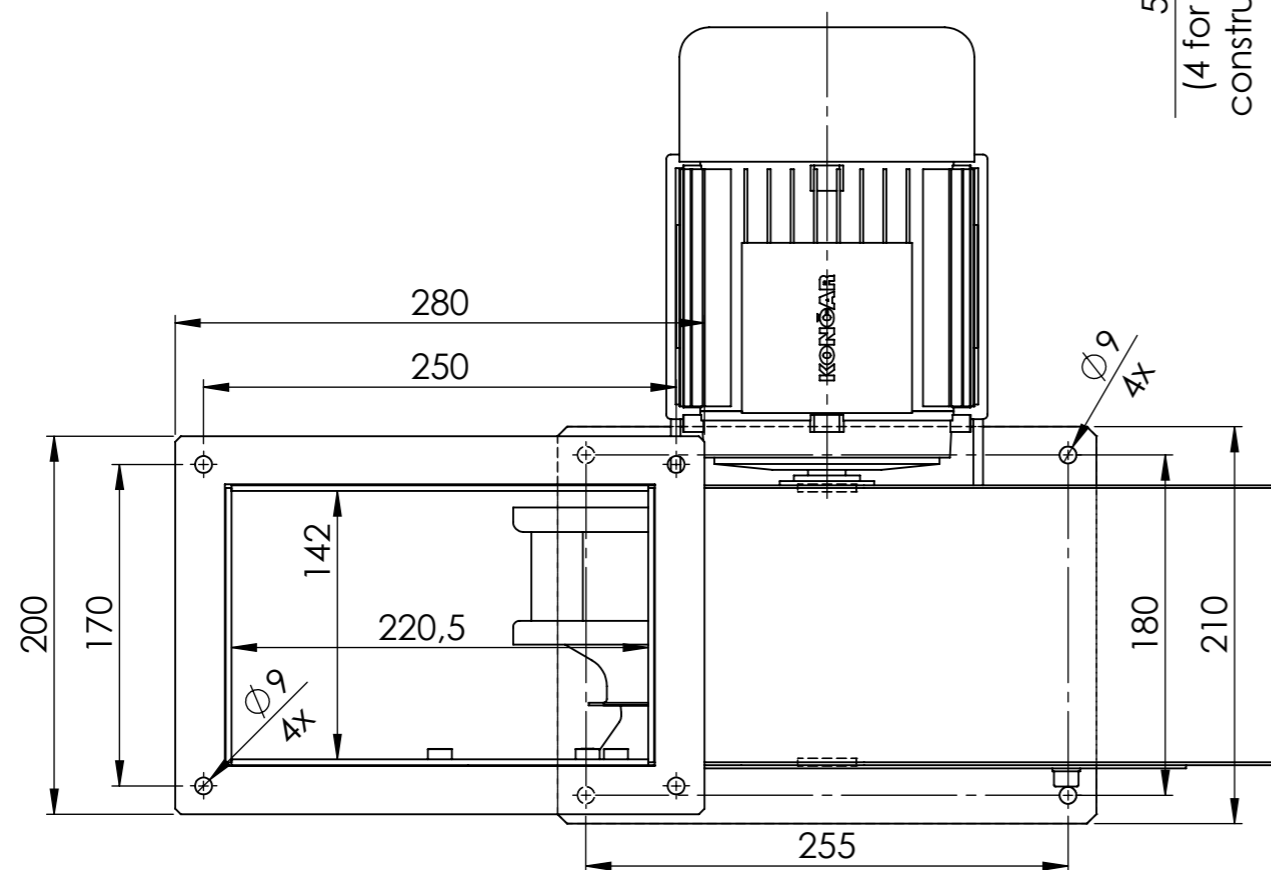
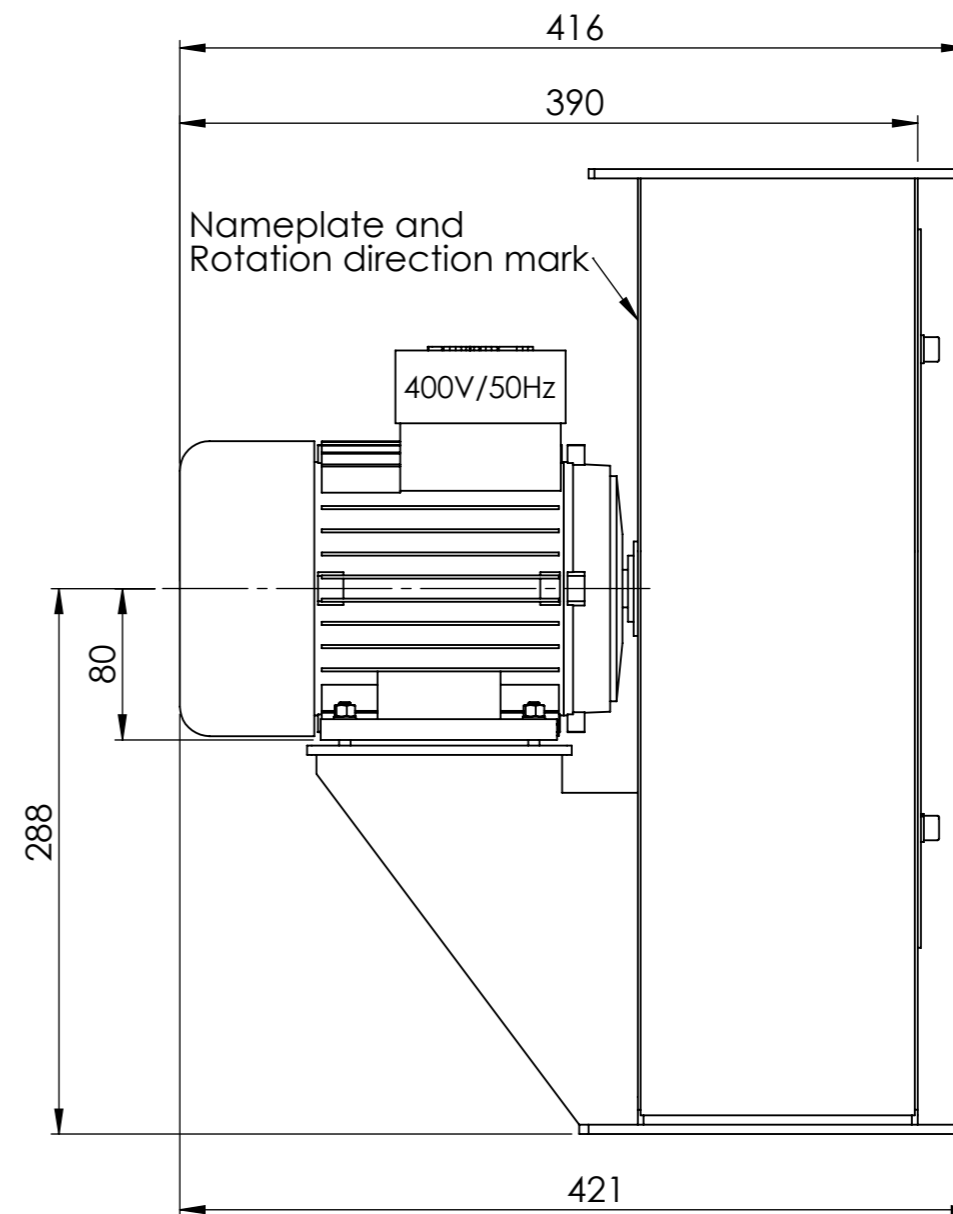
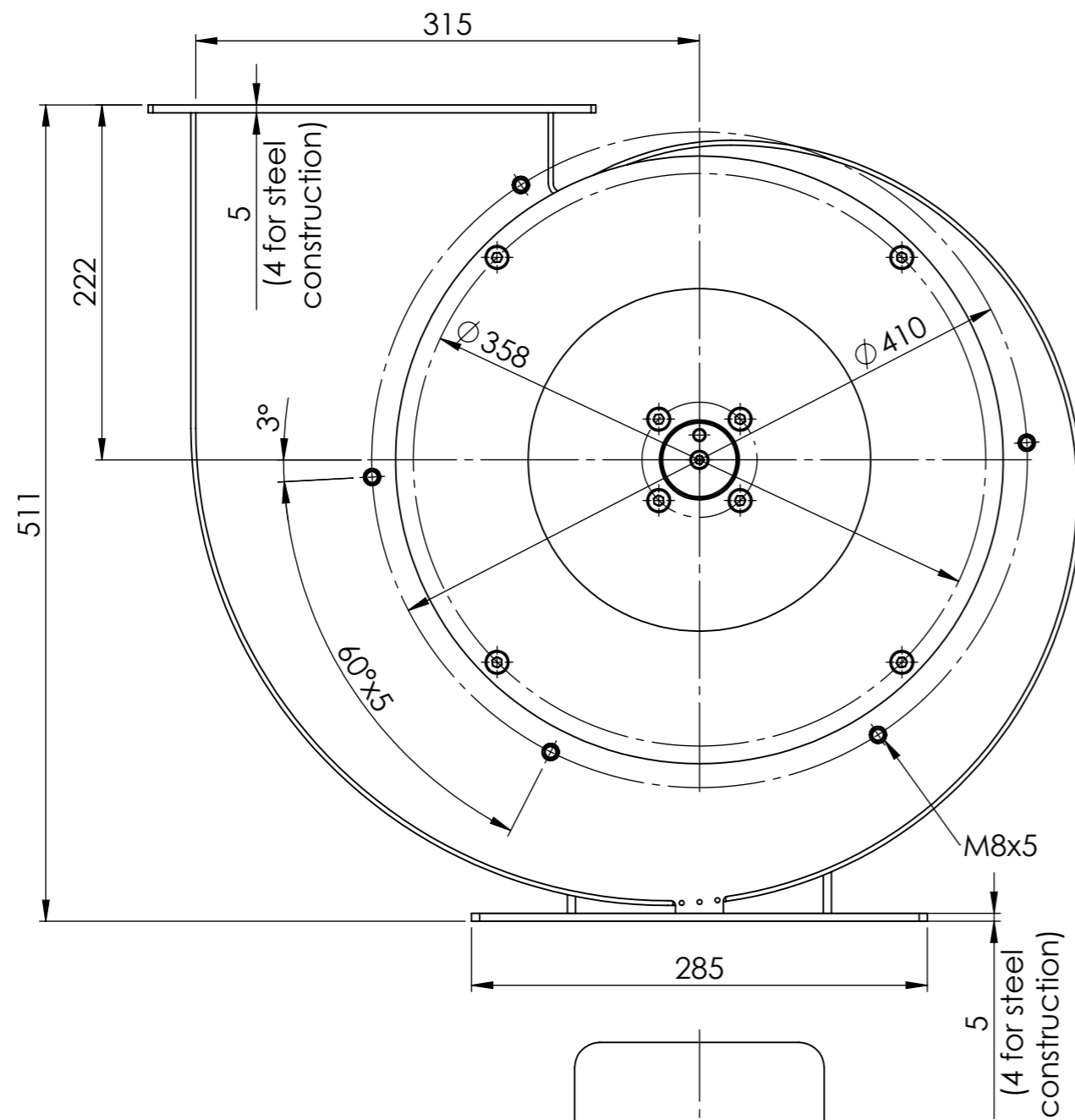

Fan wheel for all types is made from steel

Designation	Spiral casing material	Part No.	Mass (kg)
Type 7 NCV 315S-2830	Steel	BI 34127	30
Type 7 NCV 315S-2820	AlMg3	BI 34131	23
Type 8 NCV 315S-1410/2830	Steel	BI 34135	30
Type 8 NCV 315S-1410/2830	AlMg3	BI 34139	23

Type of device: Centrifugal ventilator		Series: NCV 315S	Direction: Exhaust Up
BRKIC IZUMI ZAGREB	Sheet size: A3	Dimensions in mm Tolerances ±1 unless shown	First angle projection
			Drawing sheets: 1/1

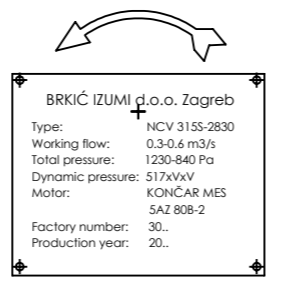
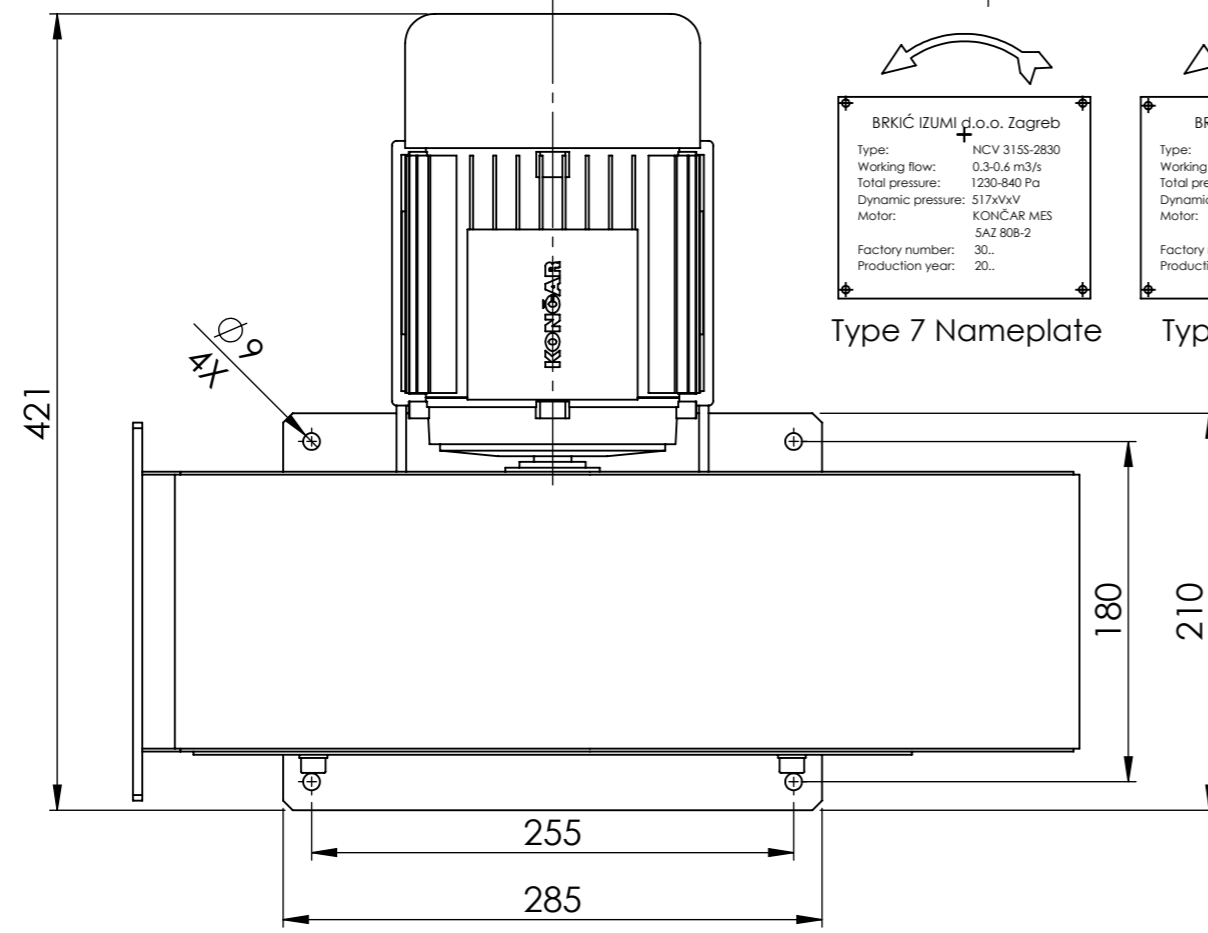
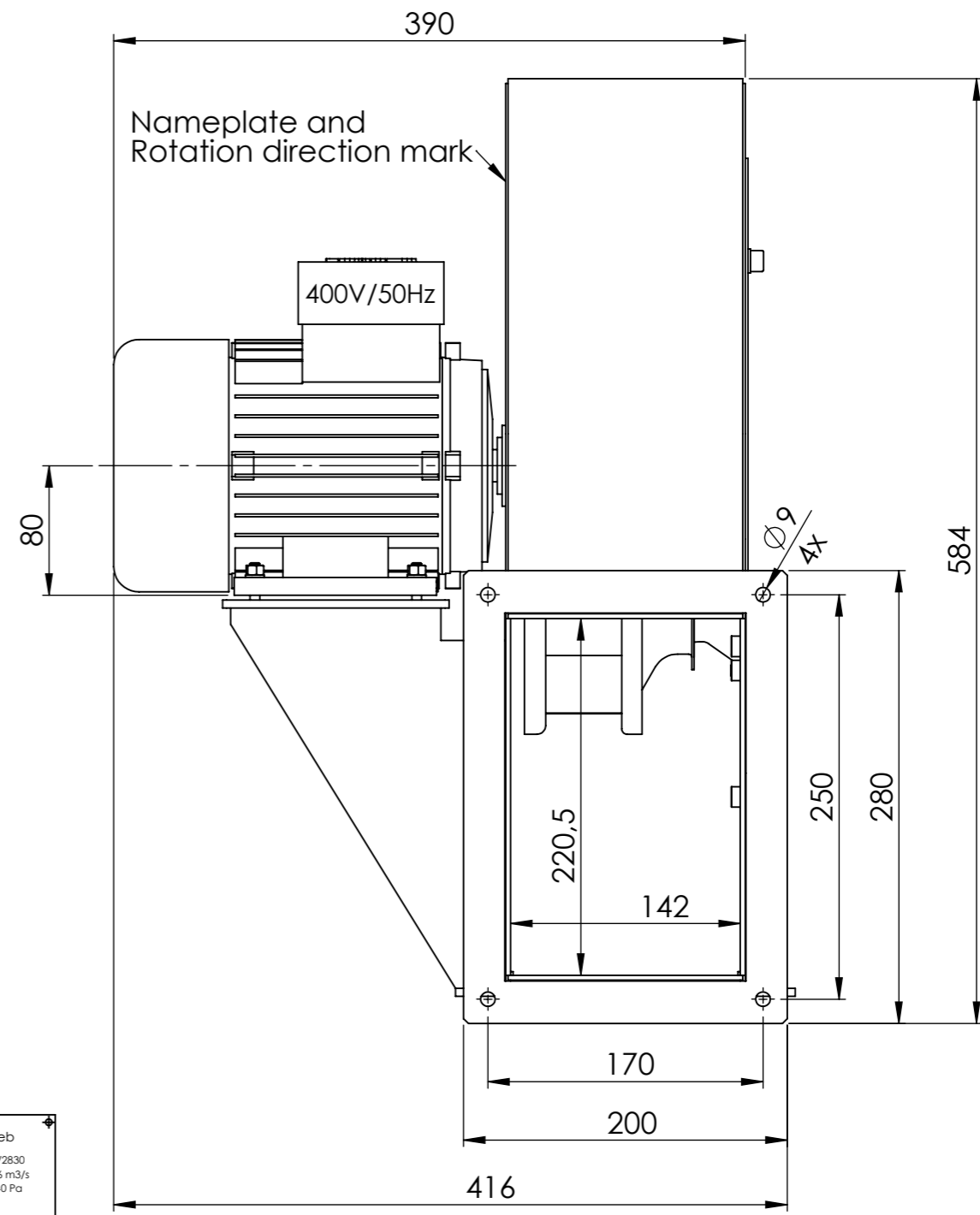
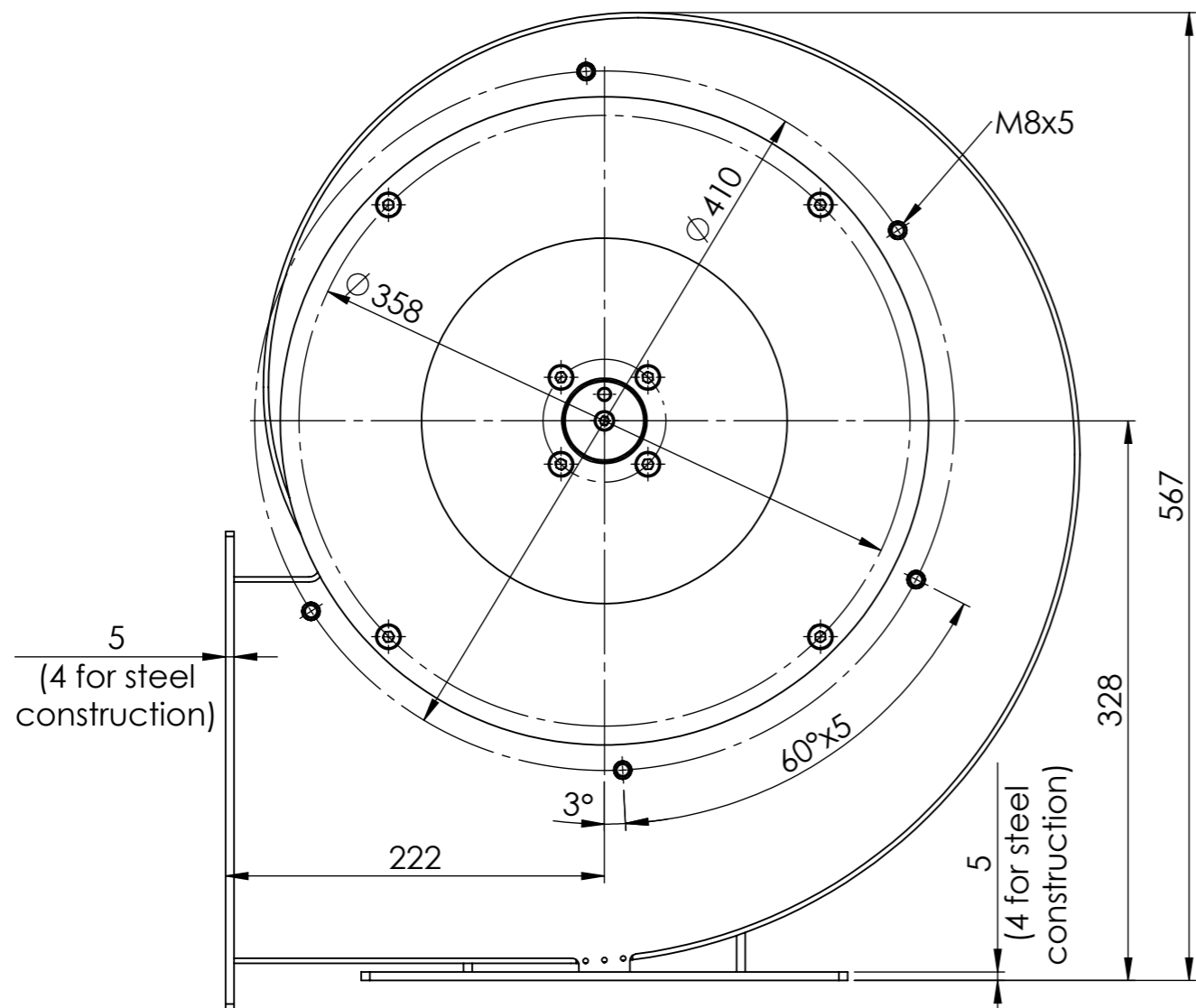

Type 7 Nameplate

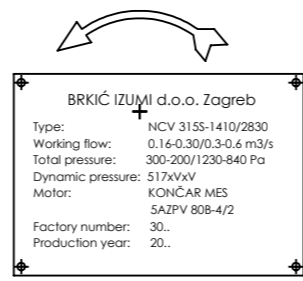

Type 8 Nameplate

Fan wheel for all types is made from steel

Designation	Spiral casing material	Part No.	Mass (kg)
Type 7 NCV 315S-2830	Steel	BI 34128	30
Type 7 NCV 315S-2820	AlMg3	BI 34132	23
Type 8 NCV 315S-1410/2830	Steel	BI 34136	30
Type 8 NCV 315S-1410/2830	AlMg3	BI 34140	23

Type of device: Centrifugal ventilator		Series: NCV 315S	Direction: Exhaust Left	
BRKIĆ IZUMI ZAGREB	Sheet size: A3	Dimensions in mm Tolerances ±1 unless shown	First angle projection	Drawing sheets: 1/1